

TRE

TRE Rohrbach AG
Beleuchtungen

tre.ch | +41 (0) 44 853 43 53

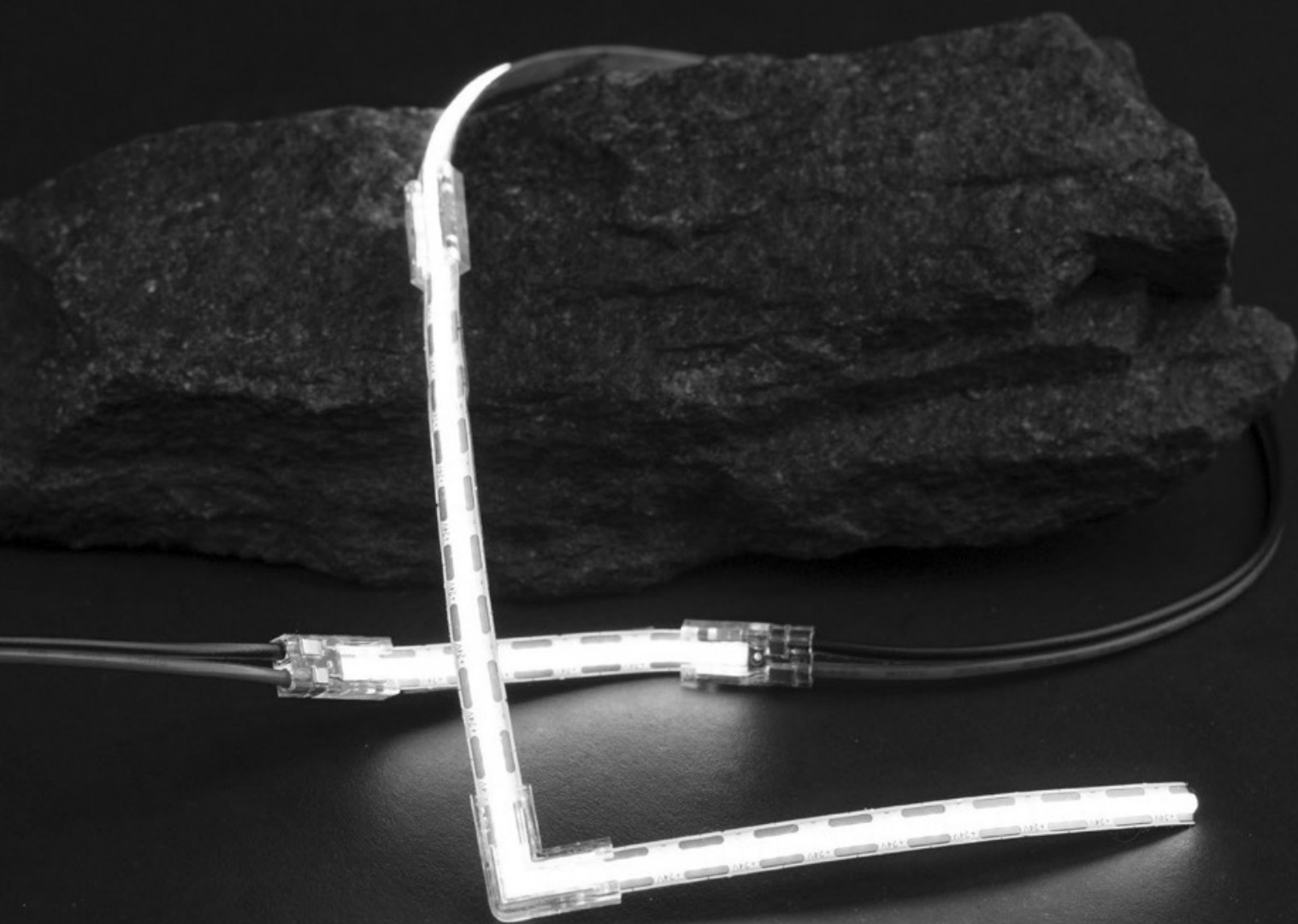

Adresse

TRE Rohrbach AG
Gewerbstrasse 11
8162 Steinmaur
+41 (0) 44 853 43 53
info@tre.ch
www.tre.ch

Öffnungszeiten

Montag - Freitag
08:00 - 12:00 Uhr
13:00 - 17:00 Uhr
(Freitag 16:00 Uhr)

Showroom

Besuch nur nach telefonischer Voranmeldung unter: 044 853 43 53

Parkieren

Gratisparkplätze vorhanden

Informationen

Die angegebenen Preise sind in CHF exklusive MWSt. und vRG.
Preis-, Konstruktions- und Massänderungen bleiben vorbehalten.
Abbildungen sind unverbindlich in Farbe, Form und Ausführung.
Es gelten die allgemeinen Geschäftsbedingungen der TRE Rohrbach AG.

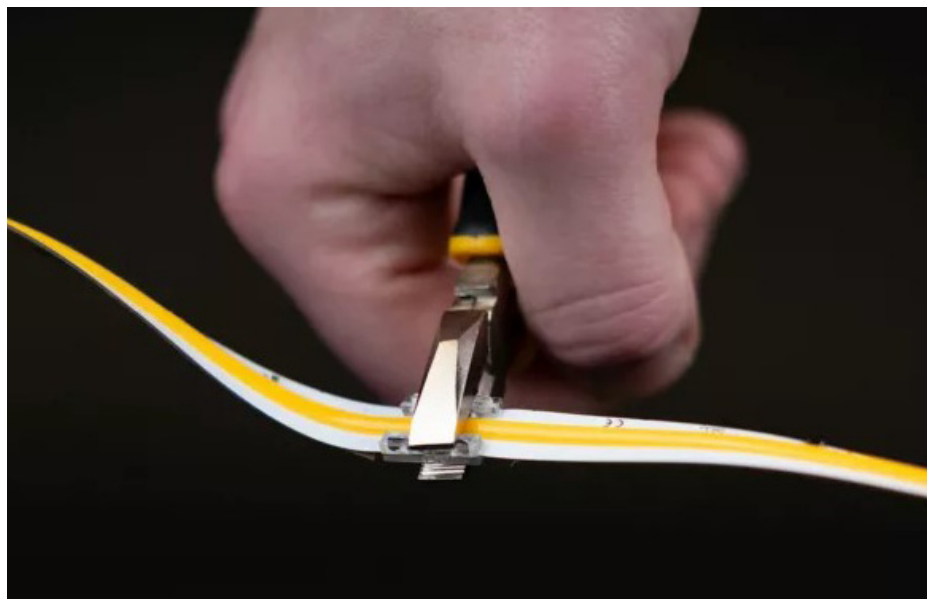

Auf Wiedersehen Löten, hallo Steckverbinder!

Mit unseren neuen Schnellverbindern wird die Installation unserer COB LED-Strips IP20 so einfach wie nie! Dank praktischer Einspeisungen und verschiedenen Verbindern lassen sich die Strips einfach anschliessen und verbinden – schnell, sauber, ohne Reste und ohne Lötten!

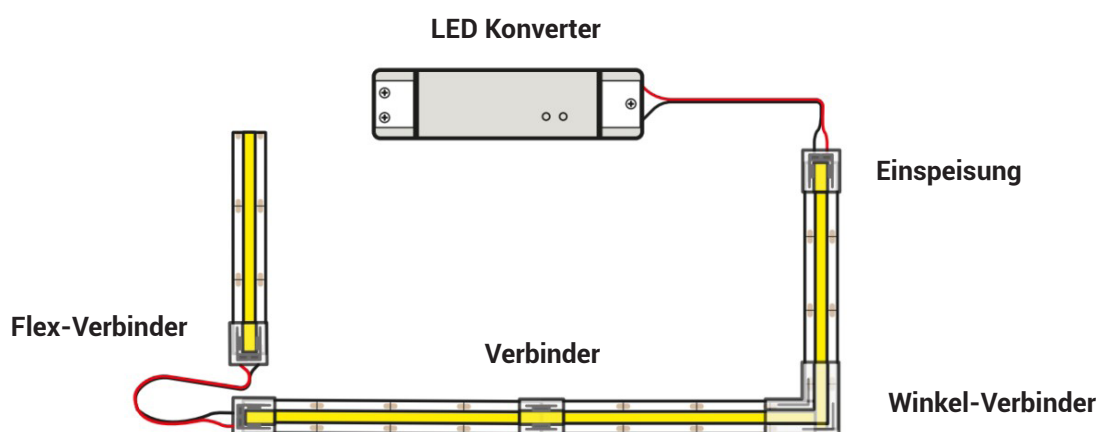

Der vielbeschäftigte Elektriker



Die Zeit ist knapp, und die Anforderungen sind hoch. Sie stehen auf der Baustelle, das Projekt drückt – die LED-Streifen sind zu lang, die Kabel zu kurz, und das Löten fühlt sich wie ein endloser Kampf an.

Das muss nicht sein!

Alles was Sie brauchen aus einer Hand

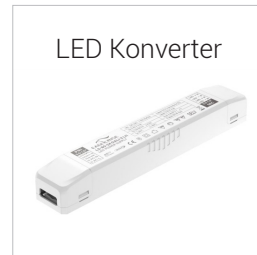
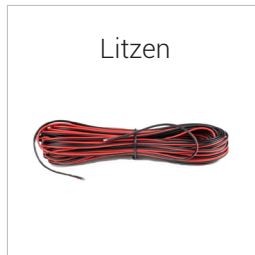
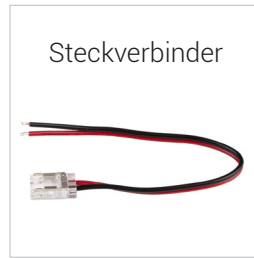
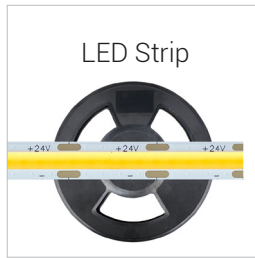

Nie mehr löten!
Stecken, klemmen fertig

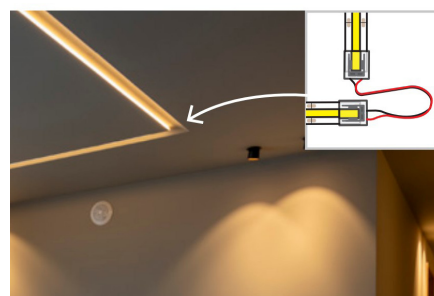
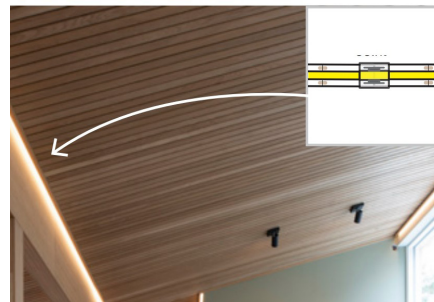
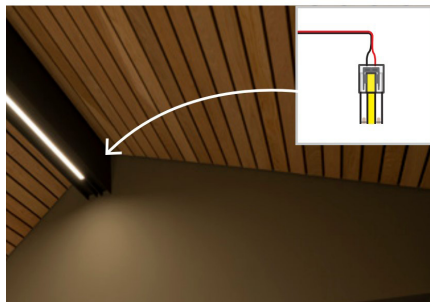

COB V2

LED Strip 24V - der perfekte Standardstrip bis 5m pro Anschluss

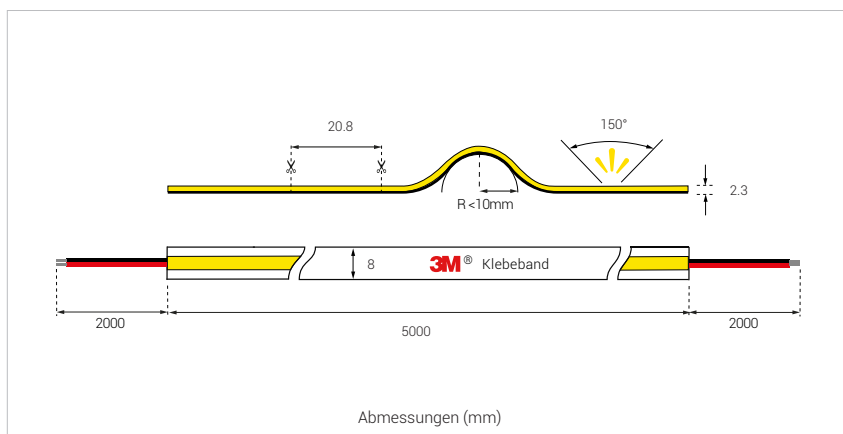

Bezeichnung	Zusatz	Artikelnummer	Listenpreis CHF
LED Strip COB V2, IP20, 2700°K, 1070lm/m, CRI90	24VDC, 10W/m, Cut 20.8mm, Rolle 5m	LS-011-927	179.00
LED Strip COB V2, IP20, 3000°K, 1070lm/m, CRI90	24VDC, 10W/m, Cut 20.8mm, Rolle 5m	LS-011-930	179.00
LED Strip COB V2, IP20, 4000°K, 1070lm/m, CRI90	24VDC, 10W/m, Cut 20.8mm, Rolle 5m	LS-011-940	179.00

Passende Steckverbinder - für LED Strip COB V2

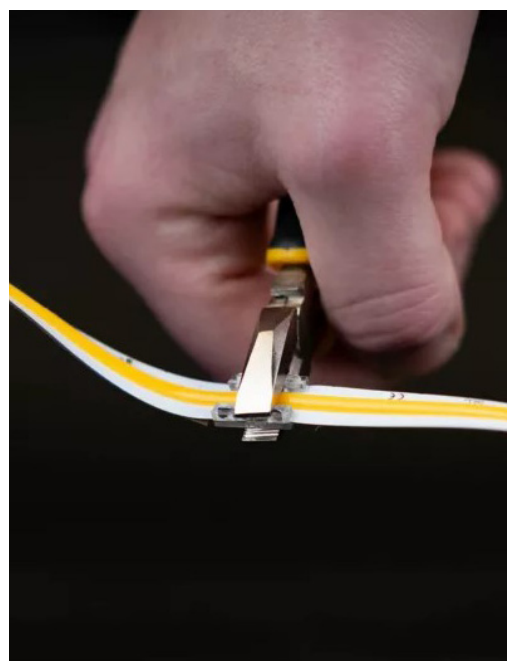

COB ULTRA LONG

LED Strip 24V - bis 15m pro Anschluss

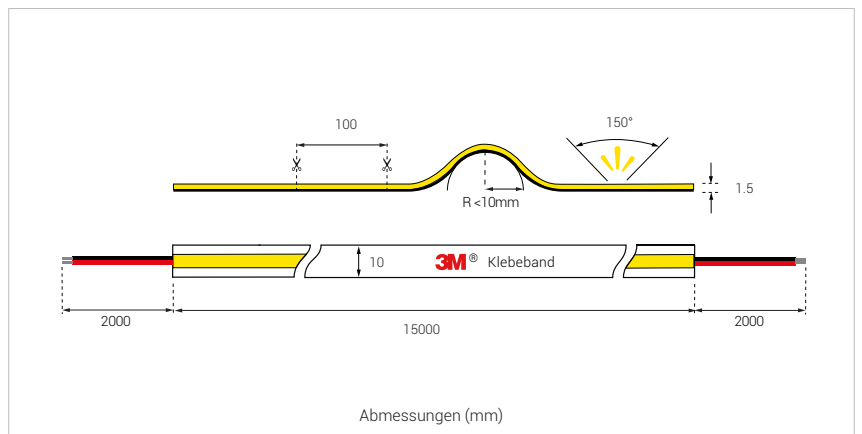

Bezeichnung	Zusatz	Artikelnummer	Listenpreis CHF
LED Strip COB ULTRA LONG, IP20, 2700°K, 720lm/m, CRI90	24VDC, 8W/m, Cut 100mm, Rolle 15m	LS-021-927	429.00
LED Strip COB ULTRA LONG, IP20, 3000°K, 760lm/m, CRI90	24VDC, 8W/m, Cut 100mm, Rolle 15m	LS-021-930	429.00
LED Strip COB ULTRA LONG, IP20, 4000°K, 800lm/m, CRI90	24VDC, 8W/m, Cut 100mm, Rolle 15m	LS-021-940	429.00

Passende Steckverbinder - für LED Strip COB ULTRA LONG

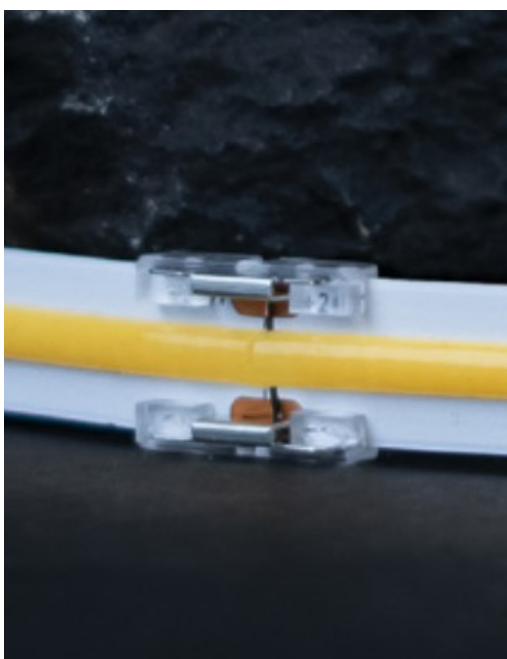

EASY A1

Anbauprofil - 2m Stangen (ohne Abdeckung)

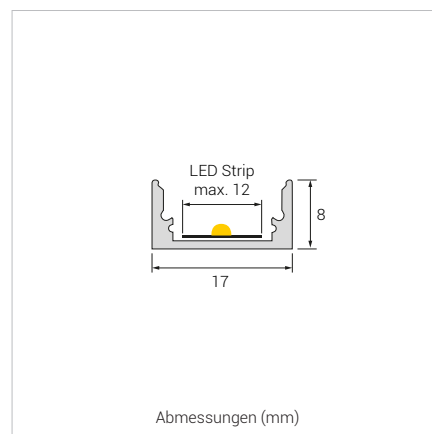

Bezeichnung	Zusatz	Artikelnummer	Listenpreis CHF
EASY A1, Aluprofil, BxH: 17x8mm	2m Stange, 5x vorgebohrte Befestigungslöcher, aluminium eloxiert	LP-101-001	20.00
EASY A1, Aluprofil, BxH: 17x8mm	2m Stange, 5x vorgebohrte Befestigungslöcher, schwarz	LP-101-002	25.00
EASY A1, Aluprofil, BxH: 17x8mm	2m Stange, 5x vorgebohrte Befestigungslöcher, weiss	LP-101-003	25.00

Passendes Zubehör - für Anbauprofil EASY A1



Montagetipp - kein Lichtunterbruch bei den Stossstellen mit der 10m Rollen Abdeckung

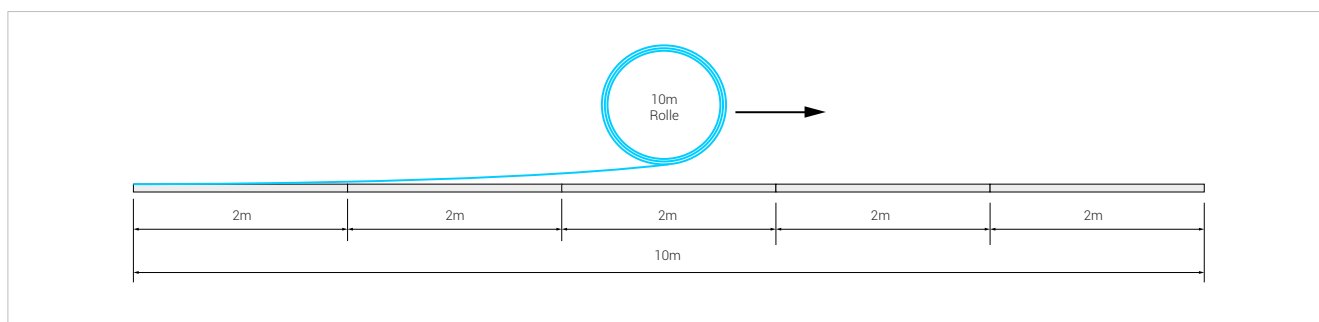

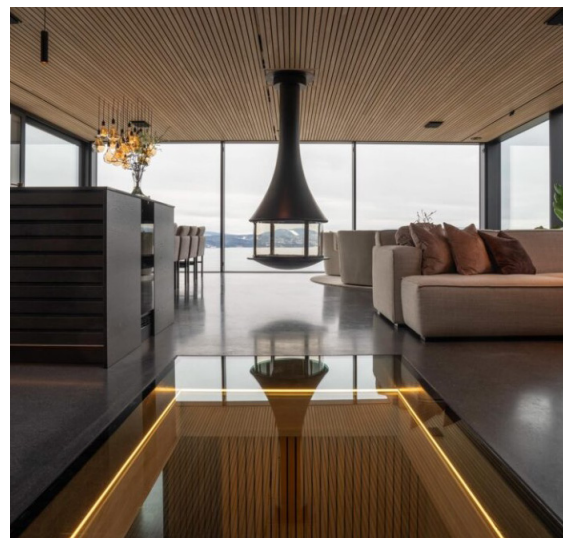

EASY DEEP

Anbau- Pendelprofil - 2m Stangen (ohne Abdeckung)

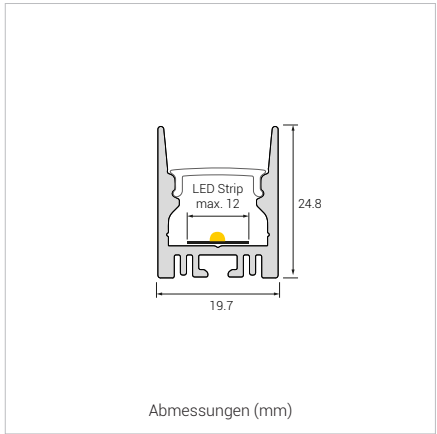

Bezeichnung	Zusatz	Artikelnummer	Listenpreis CHF
EASY DEEP, Aluprofil, BxH: 20x25mm	2m Stange, schwarz	LP-111-002	65.00
EASY DEEP, Aluprofil, BxH: 20x25mm	2m Stange, weiss	LP-111-003	65.00

Passendes Zubehör - für Anbau- Pendelprofil EASY DEEP

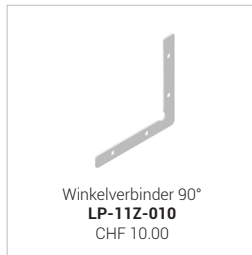

Montagetipp - kein Lichtunterbruch bei den Stossstellen mit der 10m Rollen Abdeckung

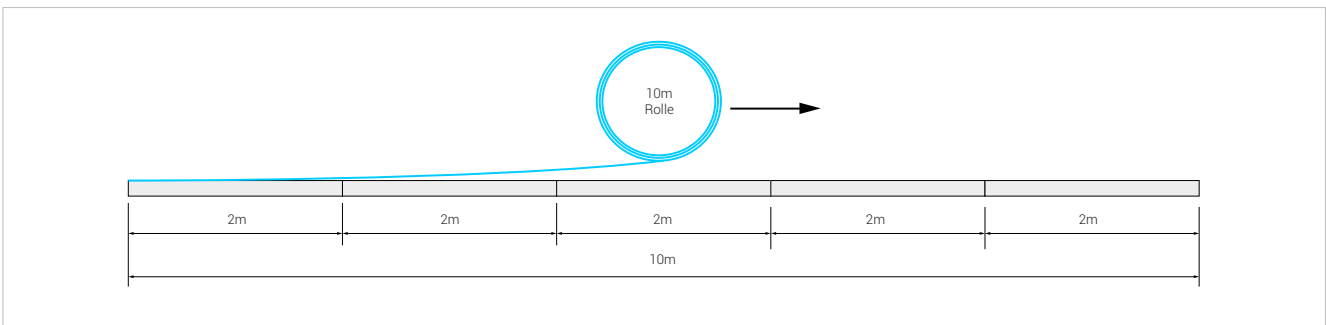



Betriebsgeräte

LED Konverter 24VDC



Bezeichnung	Zusatz	Bild	Artikelnummer	Listenpreis CHF
LED Konverter CV, Anbau, 24VDC/30W	230V, IP20, Ein/Aus	1	BG-LS-30-24-ND	31.00
LED Konverter CV, Anbau, 24VDC/75W	230V, IP20, Ein/Aus	1	BG-LS75-24-ND	48.00
LED Konverter CV, Anbau, 24VDC/120W	230V, IP20, Ein/Aus	1	BG-LS120-24-ND	68.00
LED Konverter CV, Anbau, 24VDC/150W	230V, IP20, Ein/Aus	1	BG-LS150-24-ND	76.00
LED Konverter CV, Einbau UP Dose, 24VDC/12W	230V, IP20, dimmbar PHASE	2	BG-S32059	42.00
LED Konverter CV, Anbau, 24VDC/25W	230V, IP20, dimmbar PHASE	2	BG-S32089	45.00
LED Konverter CV, Anbau, 24VDC/50W	230V, IP20, dimmbar PHASE	2	BG-S32080	59.00
LED Konverter CV, Anbau, 24VDC/100W	230V, IP20, dimmbar PHASE	2	BG-S32081	119.00
LED Konverter CV, Anbau, 24VDC/45W	230V, IP20, dimmbar DALI-2/TOUCHDIM	3	BG-LS45-24-DA2	68.00
LED Konverter CV, Anbau, 24VDC/80W	230V, IP20, dimmbar DALI-2/TOUCHDIM	3	BG-LS80-24-DA2	74.00
LED Konverter CV, Anbau, 24VDC/150W	230V, IP20, dimmbar DALI-2/TOUCHDIM	3	BG-LS150-24-DA2	109.00
LED Konverter CV, Anbau, 24VDC/100W	230V, IP20, dimmbar CASAMBI	4	BG-CAS-01000	140.00
LED Konverter & Zigbee Empfänger CV, Anbau, 24VDC/50W, MONO	230V, IP20, dimmbar Zigbee/PUSHDIM	5	TLG-S32053	135.00
LED Konverter & Zigbee Empfänger CV, Anbau, 24VDC/96W, MONO	230V, IP20, dimmbar Zigbee/PUSHDIM	5	TLG-S32054	239.00
LED Konverter & Funk Empfänger CV, Anbau, 24VDC/50W, 1-2 Kanal	230V, IP20, dimmbar FUNK/PUSHDIM	6	SRP-1009-24-50W-CV	89.00
LED Konverter & Funk Empfänger CV, Anbau, 24VDC/100W, 1-4 Kanal	230V, IP20, dimmbar FUNK/PUSHDIM	6	SRP-1009-24-100W	189.00



Zubehör



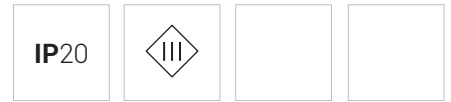







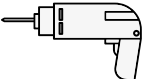
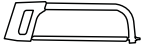

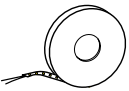
Litzen & Verbindungsklemmen

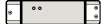

Bezeichnung	Zusatz	Bild	Artikelnummer	Listenpreis CHF
Litze 2x 0,35 mm ² (rot/schwarz)	10m	1	ZU-039-001	19.00
Litze 2x 0,35 mm ² (rot/schwarz)	100m	2	ZU-039-002	159.00
Litze 2x 0,75 mm ² (rot/schwarz)	10m	1	ZU-039-003	29.00
Litze 2x 0,75 mm ² (rot/schwarz)	100m	2	ZU-039-004	239.00
Verbinder, 1-fach	für Litzen von 0,35 mm ² bis 0,75 mm ²	3	ZU-038-001	9.00
Verbinder, 2-fach	für Litzen von 0,35 mm ² bis 0,75 mm ²	4	ZU-038-002	9.00
T-Verbinder, 1-fach	für Litzen von 0,35 mm ² bis 0,75 mm ²	5	ZU-038-003	9.00
T-Verbinder, 2-fach	für Litzen von 0,35 mm ² bis 0,75 mm ²	6	ZU-038-004	9.00

LED Easy Checkliste - Was Sie für eine erfolgreiche Installation benötigen & beachten sollten



Bohrer 	Eisensäge 	Profil 	Abdeckung 	LED Strip 
Messband 	Schere 			Steckverbinder Kabel 
Klebeband 	Zange 			LED Konverter 
Schrauben 	Dübel 		Endkappen / Clips 	

Nicht seitlich biegen

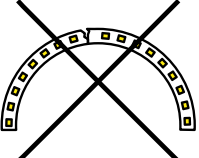

Nicht knicken



Betrieb nur mit 24VDC

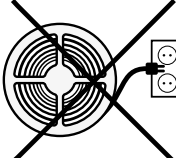

Biegeradius beachten



Projektplanung

Objekt

Datum



LED Strip



Profil

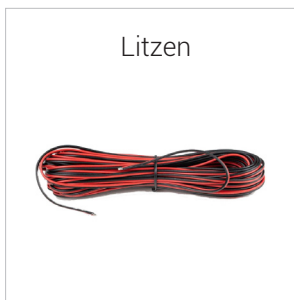

Litzen

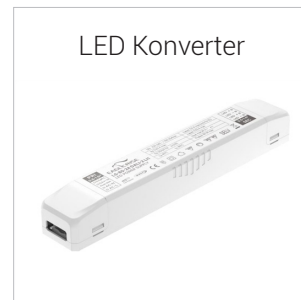

LED Konverter

Länge

Länge

Länge

Leistung

Striptyp

- COB V2
- COB ULTRA LONG

Lichtfarbe

- 2700°K
- 3000°K
- 4000°K

Steckverbinder

- Einspeisung 150mm
- Einspeisung 2000mm
- Flex-Verbinder
- Verbinder
- Winkel-Verbinder

Profiltyp

- A1
- DEEP

Profilfarbe

- alu
- weiss
- schwarz

Befestigung

- geschraubt
- Halteklammern
- Seilabhängung
- kleben

Querschnitt

- 0,35 mm²
- 0,75 mm²

Litzenverbinder

- Verbinder 1-fach
- Verbinder 2-fach
- T-Verbinder 1-fach
- T-Verbinder 2-fach

Regulierung

- Ein/Aus
- Phaseabschnitt
- DALI / Touchdim
- Casambi
- Zigbee
- Funk



Skizze

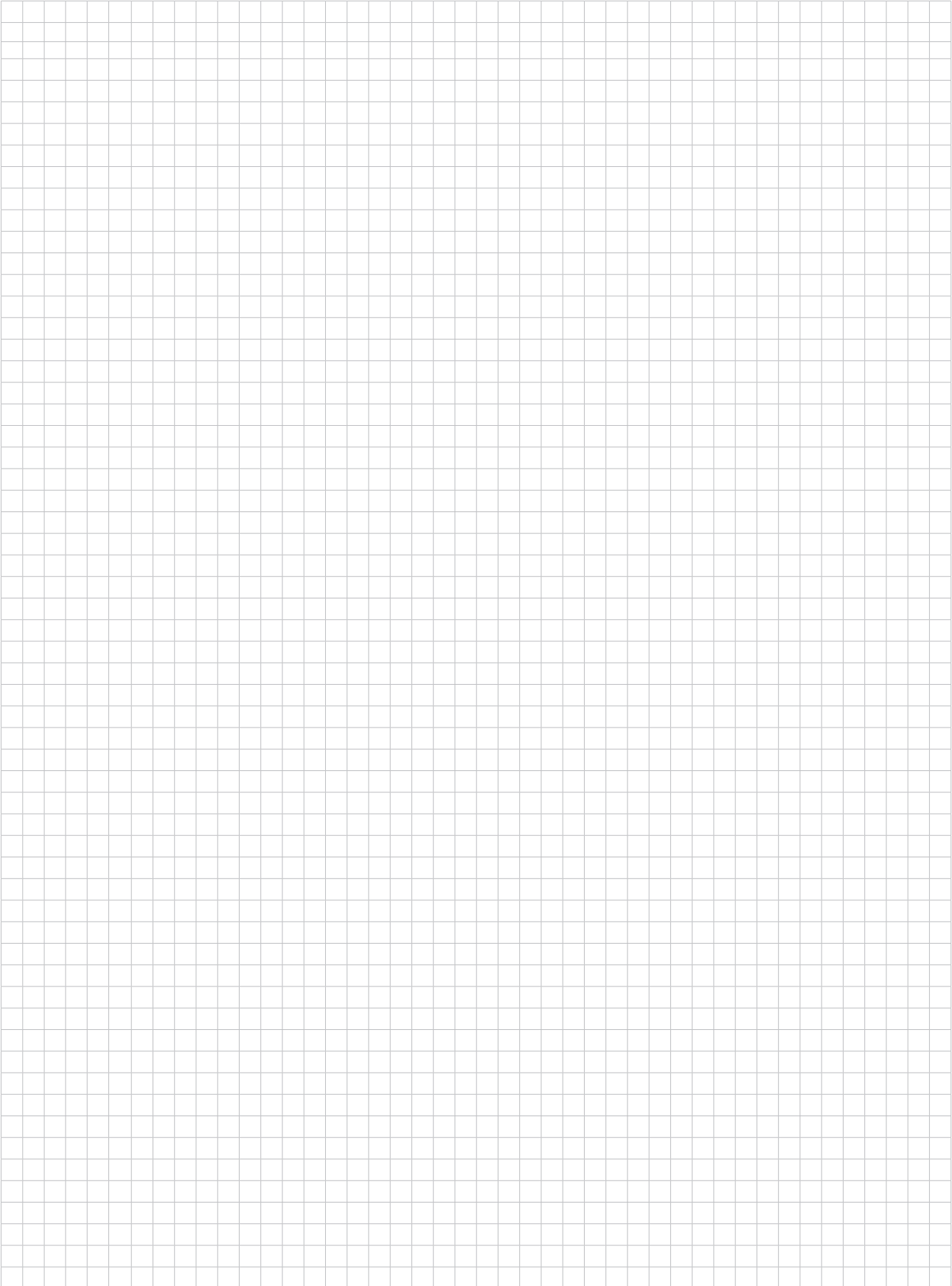



TRE

Ihr Partner
für Beleuchtungen
seit 1990

Adresse

TRE Rohrbach AG
Gewerbestrasse 11
8162 Steinmaur
+41 (0) 44 853 43 53
info@tre.ch
www.tre.ch

Öffnungszeiten

Montag - Freitag
08:00 - 12:00 Uhr
13:00 - 17:00 Uhr
(Freitag 16:00 Uhr)

Kontaktformular

Scannen, ausfüllen
und abschicken. Wir
beraten Sie gerne!

Showroom

Besuch nur nach
telefonischer
Vorankündigung unter:
044 853 43 53

Parkieren

Gratisparkplätze vorhanden

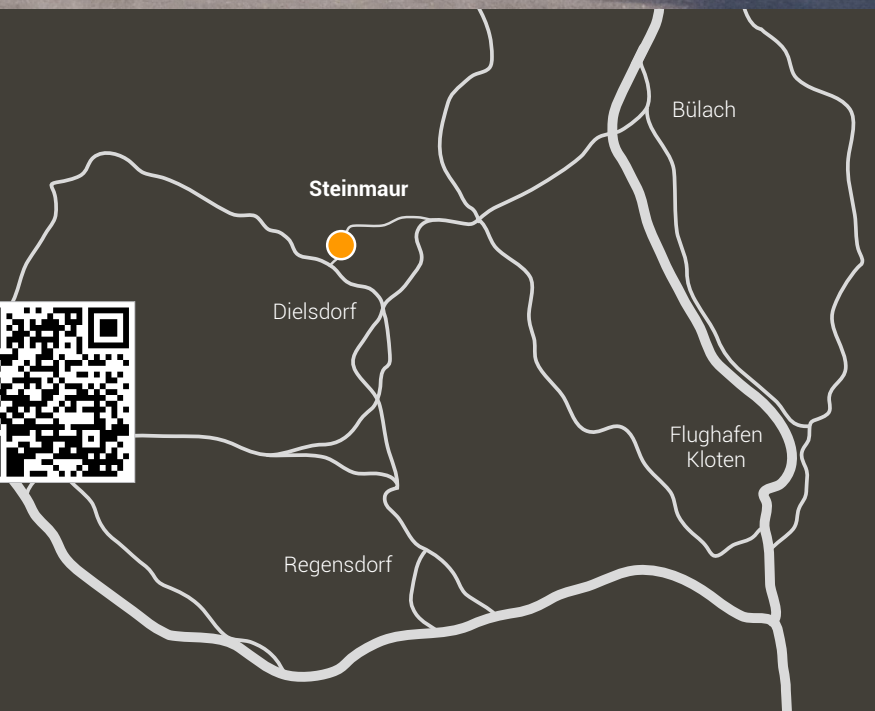

Standardprodukte

Licht nach Mass

Lichtsanierung

Lichtprojekte